

SHARP

No.	LCY - 02063A
DATE	June . 6 . 2002

TECHNICAL LITERATURE
FOR
TFT - LCD module

MODEL No. **LQ065Y5DG01**

The technical literature is subject to change without notice.
So , please contact Sharp or its representative before
designing your product based on this literature.

SHARP CORPORATION
ENGINEERING DEPARTMENT.
MOBILE LCD DESINE CENTER
MOBILE LIQUID CRYSTAL DISPLAY GROUP

NOTICE

This publication is the proprietary of SHARP and is copyrighted, with all rights reserved. Under the copyright laws, no part of this publication may be reproduced or transmitted in any form or by any means, electronic or mechanical for any purpose, in whole or in part, without the express written permission of SHARP. Express written permission is also required before any use of this publication may be made by a third party.

The application circuit examples in this publication are provided to explain the representative applications of SHARP's devices and are not intended to guarantee any circuit design or permit any industrial property right or other rights to be executed. SHARP takes no responsibility for any problems related to any industrial property right or a third party resulting from the use of SHARP's devices, except for those resulting directly from device manufacturing processes.

In the absence of confirmation by device specification sheets, SHARP takes no responsibility for any defects that occur in equipment using any of SHARP's devices, shown in catalogs, data books, etc. Contact SHARP in order to obtain the latest device specification sheets before using any SHARP's device.

SHARP reserves the right to make changes in the specifications, characteristics, data, materials, structures and other contents described herein at any time without notice in order to improve design or reliability. Contact SHARP in order to obtain the latest specification sheets before using any SHARP's device. Manufacturing locations are also subject to change without notice.

Observe the following points when using any device in this publication. SHARP takes no responsibility for damage caused by improper use of the devices.

The devices in this publication are designed for use in general electronic equipment designs, such as:

- Car Navigation system
- Automotive auxiliary information display
- Automotive audio visual equipment

The appropriate design measures should be taken to ensure reliability and safety when SHARP's devices are used for equipment such as:

- Transportation control and safety equipment (i.e., aircraft, trains, automobiles, etc.)
- Traffic signals
- Gas leakage sensor breakers
- Alarm equipment
- Various safety devices etc.

SHARP's devices shall not be used for equipment that requires extremely high level of reliability, such as:

- Military and space applications
- Nuclear power control equipment
- Medical equipment for life support

Contact a SHARP representative, in advance, when intending to use SHARP's devices for any "specific" applications other than those recommended by SHARP.

Contact and consult with a SHARP representative if there are any questions about the contents of this publication.

1. Application

The SHARP Color TFT-LCD module is an active matrix LCD (Liquid Crystal Display) produced by making the most of Sharp's expertise in liquid-crystal and semiconductor technologies.

The active device is amorphous silicon TFT (Thin Film Transistor).

Module geometry(Mechanical specification) : Table 4-1

2. Summary and Features

- It corresponds to a wide screen by using the panel of aspect ratio 15:9.
- The 6.5 screen produces a high resolution image that is composed of 384,000 pixels elements in a stripe arrangement.
- Graphics and texts can be displayed on a 800 × RGB × 480 dots panel with 262,144 colors by supplying 18 bit data signals(6 bit/color).
- By adopting an active matrix drive, a picture with high contrast is realized.
- Reduced reflection as a result of low reflection black matrix and an antiglare (AG) polarizer being adopted.
- Wide viewing angle technology is employed. (The most suitable viewing angle is in the 6 o'clock direction.)
- By COG method, realized a slim, lightweight, and compact module.
- Through the use of TN-normally white mode, an image with highly natural color reproduction is realized.
- An inverted video display in the vertical and horizontal directions is possible.
- The backlight is excellent of brightness rising characteristics at low temperature in consideration of automotive application.

3. Construction and Outline

- The construction form figure : See Fig.1
- The module consists of a TFT-LCD panel, drivers, FPC, backlight, frame, front shielding cases.

4. Mechanical specifications

Table 4-1

Parameter	Specifications	Units	Remarks
Screen size (Diagonal)	16 [6.5 "]	cm	
Active area	144.0 (H) × 78.24(V)	mm	
Display format	800(H) × RGB × 480(V)	dots	
Dot pitch	0.06 (H) × 0.163 (V)	mm	
Pixel configuration	R,G,B Stripe configuration		
Outline dimension	157.2(W) × 89.7 (H) × 8.4(D)	mm	【Note4-1】
Mass	185(MAX)	g	

【Note 4-1】

Excluding protrusions. Typical values are given.

For detailed measurements and tolerances, please refer to Fig. 1.

5. Input terminal

5-1)TFT-LCD panel driving part

Table 5-1 terminal: CNIN1

Pin No.	Symbol	Description	Remarks
1	COM	Common electrode driving signal1	
2	COM	Common electrode driving signal1	
3	CS	Common electrode driving signal2	
4	CS	Common electrode driving signal2	
5	VSHA	Power supply for source driver (Analog).	
6	VSHA	Power supply for source driver (Analog).	
7	PS	Test terminal for source driver(please connect to GND)	
8	R0	RED data signal(LSB)	
9	R1	RED data signal	
10	R2	RED data signal	
11	R3	RED data signal	
12	R4	RED data signal	
13	R5	RED data signal(MSB)	
14	GND	Ground	
15	G0	GREEN data signal(LSB)	
16	G1	GREEN data signal	
17	G2	GREEN data signal	
18	G3	GREEN data signal	
19	G4	GREEN data signal	
20	G5	GREEN data signal(MSB)	
21	GND	Ground	
22	SPOI	Start signal1 for source driver.	【Note5-1】
23	V10	The Power supply for gray image	
24	V9	The Power supply for gray image	
25	V7	The Power supply for gray image	
26	V5	The Power supply for gray image	
27	V3	The Power supply for gray image	
28	V0	The Power supply for gray image	
29	GND	Ground	
30	DCLK	Clock signal for source driver.	
31	GND	Ground	
32	LS	Data transfer signal for source driver.	
33	VSHD	Power supply for source driver. (Digital)	
34	VSHD	Power supply for source driver. (Digital)	
35	GND	Ground	
36	B0	BLUE data signal(LSB)	
37	B1	BLUE data signal	
38	B2	BLUE data signal	
39	B3	BLUE data signal	
40	B4	BLUE data signal	
41	B5	BLUE data signal(MSB)	
42	GND	Ground	
43	LBR	Selection for horizontal scanning direction	【Note5-1】
44	GND	Ground	
45	SPIO	Start signal2 for source driver.	【Note5-1】

Table5-2 terminal: CNIN2

Pin No.	Symbol	Description	Remarks
1	COM	Common electrode driving signal1	
2	COM	Common electrode driving signal1	
3	CS	Common electrode driving signal2	
4	CS	Common electrode driving signal2	
5	OPEN	Non connection (Don't connect)	
6	VDD	Power supply for TFT's turn on voltage.	
7	VLS(G)	Power supply for input level shifter	
8	MODE2	Output mode changing terminal 2	【Note5-2】
9	MODE1	Output mode changing terminal 1	【Note5-2】
10	R/L	Selection for vertical scanning direction	【Note5-1】
11	GND	Ground	
12	GND	Ground	
13	CLS	Clock signal for gate driver	
14	SPS	Start signal for gate driver	
15	OPEN	Non connection (Don't connect)	
16	VCC	Power supply for logic circuit in gate driver(High level).	
17	OPEN	Non connection (Don't connect)	
18	VEE	Power supply for TFT's cut off voltage	
19	OPEN	Non connection (Don't connect)	
20	VSS	Power supply for logic circuit in gate driver(Low level).	

【Note 5-1】 The control of scanning direction

Table5-3

Mode	R/L	LBR	SPOI	SPIO
Normal mode	Lo	Hi	Input	Output
Right/Left reverse mode	Lo	Lo	Output	Input
Up/Down reverse mode	Hi	Hi	Input	Output
Right/Left & Up/Down reverse mode	Hi	Lo	Output	Input

【caution】 Lo=GND , Hi=VSHD,VLS(G)

【Note 5-2】 Refer to “Notes at the time of a power supply turning on” in clause 7-1 for the start-up and the standing lowering of the power supply.

The gate driver is selected to output by setting mode 1 and mode 2..

Table5-4

MODE1	MODE2	
Hi	Hi	Normal mode
Lo	Hi	Don't use this mode.
Hi	Lo	Skip 2 pulse mode (See Fig.5-1)
Lo	Lo	The mode which fixes all the output on the VEE level

【caution】 Lo=GND , Hi=VLS(G)

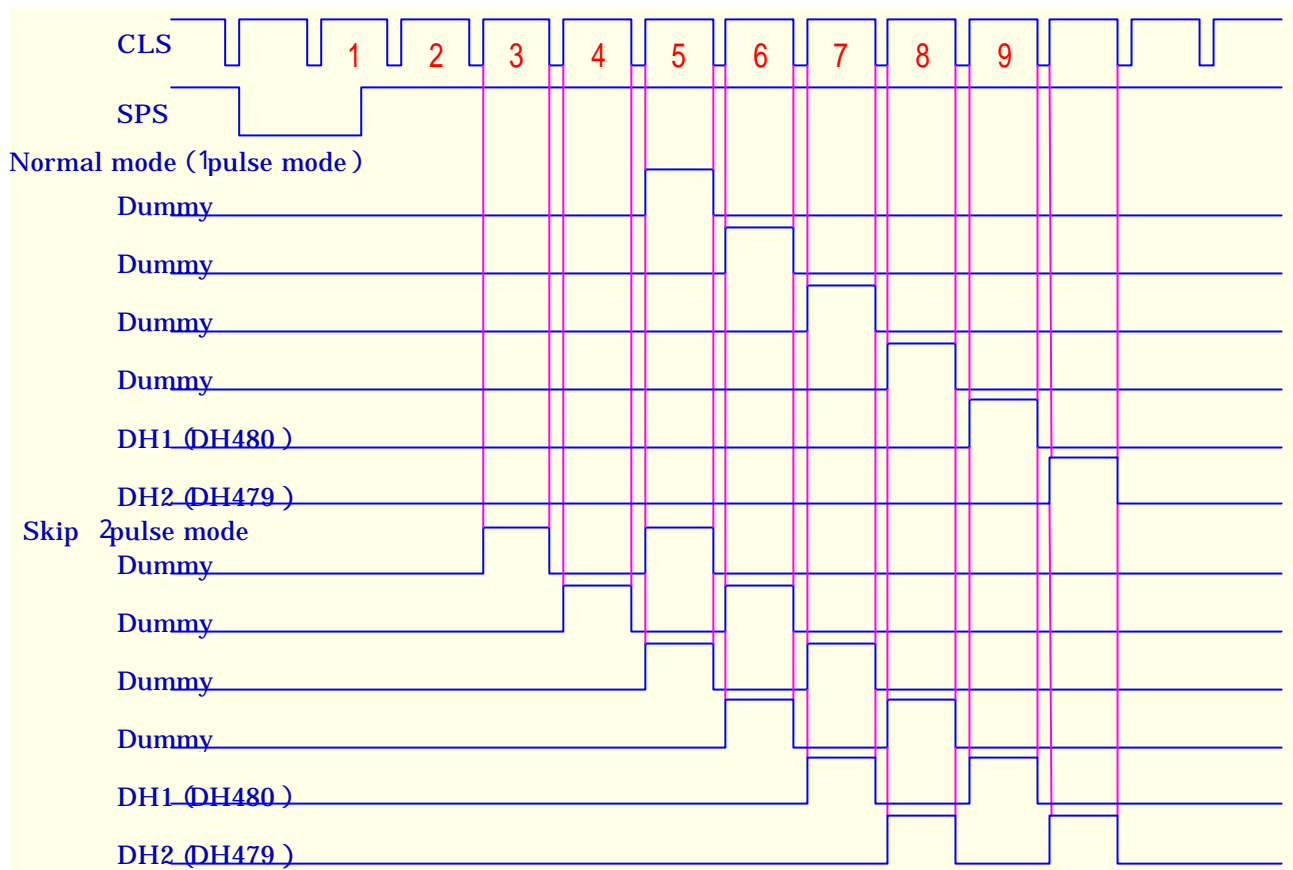

Fig5-1. Gate output timing

5-2) Backlight fluorescent tube driving part

Table 5- 5 terminal: CN 3

No.	Symbol	function	Remarks
1	VL1	input terminal(Hi voltage side)	
2	VL2	input terminal (Low voltage side)	【Note5-3】

【Note 5-3】 Connect the low voltage side of the DC/AC inverter used to drive the fluorescent tube to GND of the inverter circuit.

6. Absolute maximum ratings

Table 6-1

GND = 0 V

Parameter		Symbol	MIN	MAX	Unit	Note
Power supply (source driver)	Analog voltage	VSHA	- 0.3	+6.0	V	T a = 2 5
	Digital voltage	VSHD	- 0.3	+6.0	V	"
Power supply (gate driver)		VDD	- 0.3	+35.0	V	"
		VLS(G)	- 0.3	+6.0	V	"
		VCC-VSS	- 0.3	+6.0	V	"
		VEE-VSS	- 0.3	+35.0	V	"
		VDD- VEE(VSS)	- 0.3	+35.0	V	"
Input signal voltage (source driver)	Digital input signal	VID(S)	- 0.3	VSHD+0.3	V	" 【Note 6-1】
	Analog input signal	VIA	- 0.3	VSHA+0.3	V	" 【Note 6-2】
Input signal voltage (gate driver)		VID(G)	- 0.3	VLS(G)+0.3	V	" 【Note 6-3】
Common electrode driving signal		COM	- 4	+6	V	"
Storage temperature		T stg	- 40	+85		【Note 6-4,5】
Operating temperature (panel surface)		T opr1	- 30	+85		【Note 6-5,6】
Operating temperature(Ambient temperature)		T opr2	- 30	+65		【Note 6-7】

【Note 6-1】 SPOI , SPIO , R0 ~ R5 , G0 ~ G5 , B0 ~ B5 ,LS , DCLK , LBR

【Note 6-2】 V0 , V3 , V5 , V7 , V9 , V10

【Note 6-3】 MODE1 , MODE2 , R/L , SPS , CLS

【Note 6-4】 This rating applies to all parts of the module and should not be exceeded.

【Note 6-5】 Maximum wet-bulb temperature is 58 .Condensation of dew must be avoided as electrical current leaks will occur, causing a degradation of performance specifications.

【Note 6-6】 The operating temperature only guarantees operation of the circuit.

For contrast, speed response, and other factors related to display quality, determine operating temperature using the formula $T_a = + 25$

【Note 6-7】 Ambient temperature when the backlight is lit (reference value).

7. Electrical characteristics

7-1) TFT-LCD panel driving section

Table 7-1

GND = 0 V , T a = 2 5

Parameter		Symbol	MIN	TYP	MAX	Unit	Remarks	
Power supply (source driver)	Analog voltage	VS _{HA}	+4.5	+5.0	+5.5	V		
	Digital voltage	VS _{HD}	+3.0	+3.3	+3.6	V		
Power supply (gate driver)	TFT driving circuit	High level	V _{DD}	+14.8	+15.0	+15.2	V	
		Low level	AC	VEE _{AC}	-	COM _{AC}	-	V _{p-p}
	DC		VEE _{DC}	- 11.8	- 12.0	- 12.2	V	
	Logic circuit	High level	V _{CC}	V _{SS} +V _{LS} (G) - 0.1	V _{SS} +V _{LS} (G)	V _{SS} +V _{LS} (G)+0.1	V	【Note7-2】
		Low level	V _{SS}	-17.0	-17.4	-17.8	V	
Shift register	V _{LS} (G)	+3.0	+3.3	+3.6				
Power supply (gray image)		V ₀ ~ V ₁₀	0	-	VS _{HA}	V	【Note7-3】	
Input signal voltage for source driver	High level	VI _{HS}	0.8 × VS _{HD}	-	VS _{HD}	V	【Note7-4】	
	Low level	VI _{LS}	GND	-	0.2 × VS _{HD}	V		
Input signal current for source driver	High level	II _{HS1}	-	-	10	μA	【Note7-5】	
		II _{HS2}			400	μA	【Note7-6】	
	Low level	II _{LS}	-	-	10	μA	【Note7-4】	
Input signal voltage for gate driver	High level	VI _{HG}	0.8 × V _{LS} (G)	-	V _{LS} (G)	V	【Note7-7】	
	Low level	VI _{LG}	GND	-	0.2 × V _{LS} (G)	V		
Input signal current for gate driver	High level	II _{HG}	-	-	1.0	μA		
	Low level	II _{LG}	-	-	1.0	μA		
Common electrode driving signal	AC component	COM _{AC}	-	± 3.4	± 3.6	V _{p-p}	【Note7-8】	
	DC component	COM _{DC}	0	-	+3.0	V		

- Notes at the time of a power supply turning on

Please turn on and turn off power supply in simultaneous or the following order.

<Turn on> VS_{HD} , VS_{HA} , V_{LS}(G) → V_{SS} , V_{CC} → VEE → Logic signal → V_{DD}

<Turn off> V_{DD} → Logic signal → VEE → V_{SS}, V_{CC} → VS_{HD} , VS_{HA} , V_{LS}(G)

* Condition: V_{SS} < V_{CC}

At the MODE1 and MODE2 signals, please hold Low voltage for more than 2 vertical synchronous term after Low voltage is input at the time of a power supply turning on and V_{CC} rises completely. Then, please hold High voltage until the power supply is turned off.

【Note 7-1】 Please carry out polar reversal in the same amplitude and the same phase as V_{COM}.

【Note 7-2】 Condition: 3.0V V_{CC}-V_{SS} 3.6V

【Note 7-3】 It is a standard power supply for gray scale. Whenever the polarity of common electrode drive signal (COM) is changed, please also change this standard voltage. V₀ (black) power supply becomes the reverse characteristic of COM, and V₁₀ (white) becomes the same polarity as COM.

Please shift the center value of each power supply amplitude to the plus(+) direction according to the characteristic of liquid crystal as it will go to white side like V₃, V₅, V₇, V₉, V₁₀, if the center value of each power supply amplitude is based on the center value of V₀ (black).

After DC adjustment of COM signal is adjusted in case of the V₀ gray scale display, please adjust this amount of shifts so that a flicker does not occur in the power supply display of each gray scale.

【Note 7-4】 Apply to the terminal SPOI, R0-R5, G0-G5, B0-B5, LS, DCLK, LBR, and SPIO

【Note 7-5】 Apply to the terminal SPOI, R0-R5, G0-G5, B0-B5, LS, DCLK, LBR, and SPIO

【Note 7-6】 Apply to the terminal PS

【Note 7-7】 Apply to the terminal MODE1, MODE2, R/L, SPS, and CLS

【Note 7-8】 Please switch polarity of amplitude COMAC by center value of amplitude that is COMDC for every one level scan and every one vertical scan. Moreover, please adjust COMDC so that contrast becomes the maximum and a flicker becomes the minimum for every module.

7-2) Backlight driving section

Table 7-2

Parameter	Symbol	MIN	TYP	MAX	Unit	Remarks
lamp voltage	VL7	640	710	780	Vrms	I L = 4.5mArms
lamp current	IL	4.0	4.5	5.5	mArms	Ordinary state
	ILB	-	-	9.0	mArms	At the boost 【Note 7-9】
lamp frequency	fL	30	-	70	kHz	
Discharge pipe electric power	WL	-	3.2	-	W	When lighting up in the standard
kick-off voltage	VS	-	-	1750	Vrms	Ta=+25
		-	-	1800	Vrms	Ta= - 30

Inverter : HIU - 288 [HARISON TOSHIBA LIGHTING co. ,ltd]

(Output capasitor : 22pF , frequency : 49kHz)

【Caution】

Please use the inverter which has the one of the sine wave. With regards to the inverter, it should be negative/positive wave symmetry and the spike wave should not be occurred.

【Note 7-9】 Within 5 minutes. The temperature is less than 0 .

7-3) Timing characteristics

Timing diagrams of input signal are shown in Fig2-1, Fig2-2

Table 7-3 VSHA=+5.0V , VSHD·VLS(G)=3.3V , GND=0V , Ta=25

	Parameter	Symbol	MIN	TYP	MAX	Unit	Remarks
S O U R C E	Operating Clock frequency	fck	-	33.2	34.6	MHz	DCLK
	High level clock width	Tcwh	12	-	-	ns	
	Low level clock width	Tcwl	13	-	-	ns	
	Clock rise time	Tcr	-	-	4	ns	
	Clock fall time	Tcf	-	-	4	ns	
	Start pulse frequency	fsp	-	31.5	31.8	kHz	SPOI SPIO 【Note7-10】
	Start pulse set up time	Tsusp	4	-	-	ns	
	Start pulse hold time	Thsp	0	-	-	ns	
	Start pulse width	Twsp	1/fck	1/fck	1.5/fck	ns	
	LS pulse frequency	flp	-	fsp	-	kHz	LS
	LS pulse set up time (CLS)	Tsulp	5.0	-	-	μs	
	LS pulse set up time (SPOI,SPIO)	Tsulpsp	1/fck	-	-	ns	
	LS pulse hold time (DCLK)	Thlpck	20	-	-	ns	
	High level LS pulse wide	Twlp	1/fck	-	-	ns	
	Data set up time	Tsud	15	-	-	ns	R0 ~ R5 , G0 ~ G5 , B0 ~ B5
Data hold time	Thd	10	-	-	ns		
G A T E	Operating Clock frequency	fcls	-	fsp	-	kHz	CLS
	Clock pulse with	Twl	5.5	-	(1/fcls)-53	μs	
	Clock rise time	Trcl	-	-	1/fck	ns	
	Clock fall time	Tfcl	-	-	1/fck	ns	
	Start pulse frequency	fsps	-	60	65.0	Hz	SPS
	Start pulse set up time	Tsusps	100	-	-	ns	
	Start pulse hold time	Thsps	300	-	-	ns	
	Start pulse rise time	Trsps	-	-	100	ns	
	Start pulse fall time	Tfsps	-	-	100	ns	
	COM signal set up time	Tsucom	3	-	-	μs	
COM signal hold time	Thcom	0	-	-	μs		
COM signal rise time	Trcom	-	-	2	μs		
COM signal fall time	Tfcom	-	-	2	μs		
V0 ~ V10 signal set up time	Tsuv0	3	-	-	μs	V0,V3,V5 V7,V9,V10	
V0 ~ V10 signal hold time	Thv0	0	-	-	μs		
V0 ~ V10 signal rise time	Trv0	-	-	2	μs		
V0 ~ V10 signal fall time	Tfv0	-	-	2	μs		

【Note7-10】

The rising pulse in DCLK is existed only 1 time during Hi period (Twsp) on start pulse.

7-4) Current dissipations
table7-4

T a = 2 5

Parameter		Symbol	Conditions	M I N	T Y P	M A X	Unit
Current for source driver	Analog	ISHA	VSHA=+5.0V	-	35	85	mA
	Digital	ISHD	VSHD =+3.3V	-	6	16	mA
Current for gate driver	Hi	IDD	VDD =+15.0V	-	0.12	0.32	mA
	Lo	IEE	VEE= - 12.0±3.4V	-	- 0.03	- 0.08	mA
	Logic Hi	ICC	VCC = - 14.1V	-	0.03	0.08	mA
	Logic Lo	ISS	VSS = - 17.4V	-	- 0.07	- 0.18	mA
	Shift register	ILS(G)	VLS(G)=+3.3V	-	6	16	mA

* Max current situation :

Vertical stripe pattern alternating 21 gray scale (GS21) with 42 gray scale (GS42) every 1 dot.

Timing : fck=32MHz , fsp=30.3kHz , fsps=57.7Hz

In case of using exclusive control-IC (LZ9JG17).

7-5) Input Data Signals and Display Position on the screen

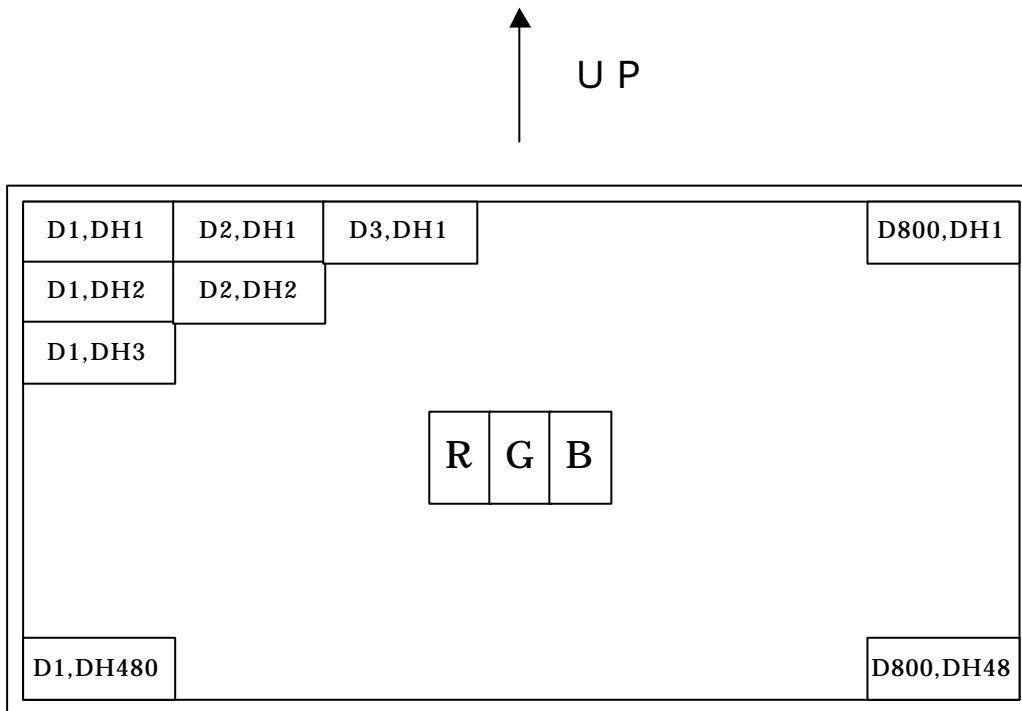

Display position of input data (H,V)

8. Input Signals, Basic Display Color and Gray Scale of Each Color

Colors & Gray scale	Data signal	0 :Low level voltage						1 :High level voltage												
		Gray Scale	R0	R1	R2	R3	R4	R5	G0	G1	G2	G3	G4	G5	B0	B1	B2	B3	B4	B5
Basic color	Black	-	0	0	0	0	0	0	0	0	0	0	0	0	0	0	0	0	0	0
	Blue	-	0	0	0	0	0	0	0	0	0	0	0	0	1	1	1	1	1	1
	Green	-	0	0	0	0	0	0	1	1	1	1	1	1	0	0	0	0	0	0
	Cyan	-	0	0	0	0	0	0	1	1	1	1	1	1	1	1	1	1	1	1
	Red	-	1	1	1	1	1	1	0	0	0	0	0	0	0	0	0	0	0	0
	Magenta	-	1	1	1	1	1	1	0	0	0	0	0	0	1	1	1	1	1	1
	Yellow	-	1	1	1	1	1	1	1	1	1	1	1	1	0	0	0	0	0	0
	White	-	1	1	1	1	1	1	1	1	1	1	1	1	1	1	1	1	1	1
Gray Scale of red	Black	GS0	0	0	0	0	0	0	0	0	0	0	0	0	0	0	0	0	0	0
	↑	GS1	1	0	0	0	0	0	0	0	0	0	0	0	0	0	0	0	0	0
	Darker	GS2	0	1	0	0	0	0	0	0	0	0	0	0	0	0	0	0	0	0
	↑	↓				↓					↓					↓				
	↓	↓				↓					↓					↓				
	Brighter	GS61	1	0	1	1	1	1	0	0	0	0	0	0	0	0	0	0	0	0
	↓	GS62	0	1	1	1	1	1	0	0	0	0	0	0	0	0	0	0	0	0
	Red	GS63	1	1	1	1	1	1	0	0	0	0	0	0	0	0	0	0	0	0
Gray Scale of green	Black	GS0	0	0	0	0	0	0	0	0	0	0	0	0	0	0	0	0	0	0
	↑	GS1	0	0	0	0	0	0	1	0	0	0	0	0	0	0	0	0	0	0
	Darker	GS2	0	0	0	0	0	0	0	1	0	0	0	0	0	0	0	0	0	0
	↑	↓				↓					↓					↓				
	↓	↓				↓					↓					↓				
	Brighter	GS61	0	0	0	0	0	0	1	0	1	1	1	1	0	0	0	0	0	0
	↓	GS62	0	0	0	0	0	0	0	1	1	1	1	1	0	0	0	0	0	0
	Green	GS63	0	0	0	0	0	0	1	1	1	1	1	1	0	0	0	0	0	0
Gray Scale of bleu	Black	GS0	0	0	0	0	0	0	0	0	0	0	0	0	0	0	0	0	0	0
	↑	GS1	0	0	0	0	0	0	0	0	0	0	0	0	1	0	0	0	0	0
	Darker	GS2	0	0	0	0	0	0	0	0	0	0	0	0	0	1	0	0	0	0
	↑	↓				↓					↓					↓				
	↓	↓				↓					↓					↓				
	Brighter	GS61	0	0	0	0	0	0	0	0	0	0	0	0	1	0	1	1	1	1
	↓	GS62	0	0	0	0	0	0	0	0	0	0	0	0	0	1	1	1	1	1
	Bleu	GS63	0	0	0	0	0	0	0	0	0	0	0	0	1	1	1	1	1	1

0 : low level voltage 1: high level voltage

Each basic color can be displayed in 64 gray scales from 6 bit data signals. According to the combination of total 18 bit data signals, the 262,144-color display can be achieved on the screen.

9. Optical characteristics

Table 9-1

Ta=25

Parameter	Symbol	Condition	Min	Typ	Max	Unit	Remarks	
Viewing angle range	21, 22	CR 5	60	65	-	° (degree)	【Note 9-1,2】	
	11		60	65	-	° (degree)		
	12		55	60	-	° (degree)		
Contrast ratio	CRmax	Optimal viewing angle	100	-	-		【Note 9-2】	
Response time	Rise	= 0 °	-	30	60	ms	【Note 9-3】	
	Fall		-	50	100	ms		
Luminance	Y	IL=4.5mArms	-	380	-	cd/m ²	【Note 9-4】	
White chromaticity	x	IL=4.5mArms	0.263	0.313	0.363		【Note 9-4】	
	y		0.279	0.329	0.379			
Lamp life time	+25	-	continuation	10,000	-	-	hour	【Note 9-5】
	- 30	-	intermission	2,000	-	-	time	【Note 9-6】

*Measuring after 30minutes operation. The measurement of the optical character is measured by using the method of fig.9-1 and fig.9-2 under the condition which is equal to the darkroom or the darkroom.

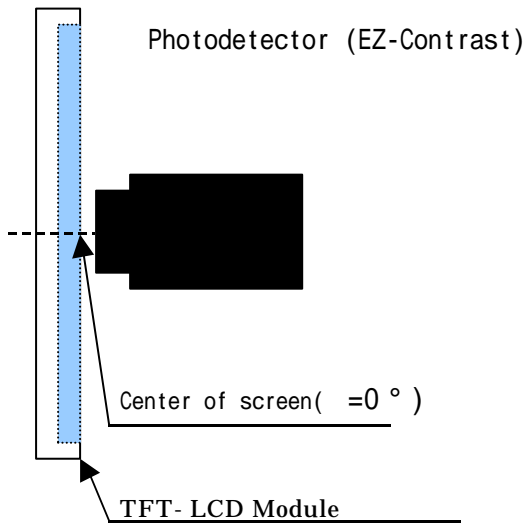

Fig9-1 Viewing angle / Range / Contrast / Response time measurement method

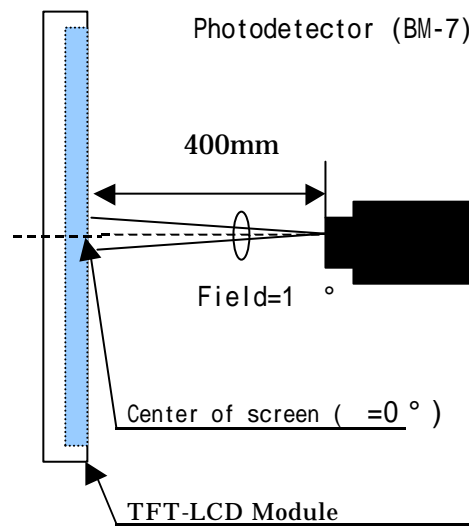
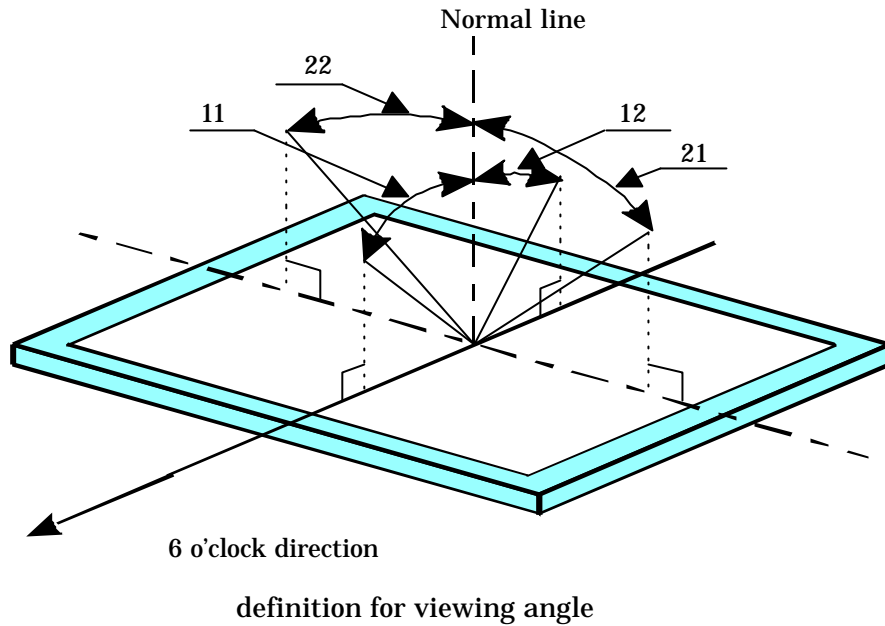

Fig9-2 Luminance / Chromaticity measurement method

【Note 9-1】 Viewing angle range is defined as follows.



【Note 9-2】 Contrast ratio of transmission is defined as follows:

$$\text{Contrast ratio(CR)} = \frac{\text{Photo detector output with LCD being "white"(GS63)}}{\text{Photo detector output with LCD being "black"(GS0)}}$$

【Note 9-3】 Response time is obtained by measuring the transition time of photo detector output, when input signals are applied so as to make the area "black" to and from "white".

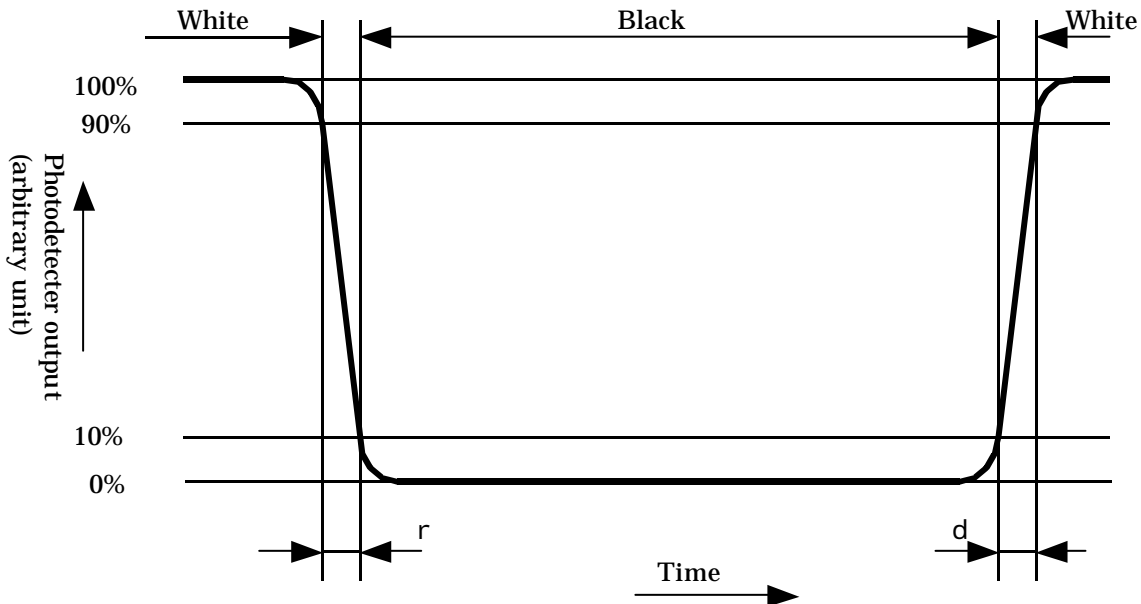

【Note 9-4】 Measured on the center area of the panel at a viewing cone 1° by TOPCON luminance meter BM-7.(After 30 minutes operation)DC/AC inverter driving frequency: 49kHz

【Note 9-5】 Lamp life time is defined as the time when the brightness of the panel not to become less than 50% of the original value in the continuous operation under the condition of lamp current $I_L=4.0 \sim 5.0\text{mA}_{rms}$ and PWM dimming 100%~5% .

【Note 9-6】 The intermittent cycles is defined as a time when brightness not to become under 50% of the original value under the condition of following cycle.

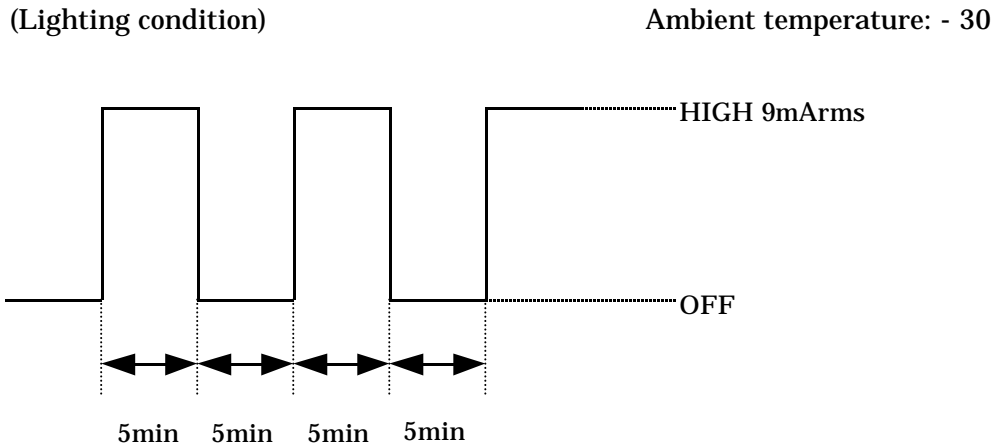

10. Display quality

The display quality of the color TFT-LCD module shall be in compliance with the Incoming Inspection Standard.

11. Mechanical characteristics

11-1) External appearance

Do not exist extreme defects. (See Fig.1)

11-2) Panel toughness

The panel shall not be broken ,when 19N is pressed on the center of the panel by a smooth sphere having 15 mm diameter.

【Caution】 In spite of very soft toughness, if, in the long-term, add pressure on the active area, it is possible to occur the functional damage.

11-3). Tensile strength of the backlight harness

Do not pull the backlight harness with the stronger power than 10N. Also, assemble it with the structure which tension isn't applied to.

11-4) I/O connector performance

A)Input/output connectors for the operation of LCD module

- 1)Applicable FPC CHIN1: IL-FHR-F45S-HF(JST)
CHIN2: IL-FHR-F20S-HF(JST)

2)FPC flexibility : Slit on the film cover lay coat part of one side printing (Fig.1 A)

If it had been tested bending under radius nothingness and bending angle 180degrees, the FPC should not be cut.(It should be bend by hand and only at once).

B)I/O connector of backlight driving circuit (JST)

Symbol	Used Connector	Corresponding connector
CN3	BHR-02(8.0)VS-1N	SM02(8.0)B-BHS-1N SM02(8.0)B-RBHK-1

12. Handling instructions

12-1) Handling of FPC

Please bend FPC only at a film cover lay slit part (Fig.1 A)

Please do not hang a LCD module or do not apply excessive power for FPC.

12-2) Mounting of module

The TFT-LCD module is designed to be mounted on equipment using the mounting tabs in the four corners of the module at the rear side.

On mounting the module, as the M2.6 tapping screw fastening torque is 0.25 through 0.35N·m is recommended, be sure to fix the module on the same plane, taking care not to wrap or twist the module.

Don't reach the pressure of touch-switches of the set side to a module directly, because images may be disturbed.

Please power off the module when you connect the input/output connector.

Please connect the metallic shielding cases of the module and the ground pattern of the inverter circuit surely. If that connection is not perfect, there may be a possibility that the following problems happen.

- a) The noise from the backlight unit will increase.
- b) The output from inverter circuit will be unstable. Then, there may be a possibility that some problems happen.
- c) In some cases, a part of module will heat.

12-3) Precautions in mounting

Polarizer which is made of soft material and susceptible to flaw must be handled carefully. Protective film (Laminator) is applied on the surface to protect it against scratches and dirties. It is recommended to peel off the laminator immediately before the use, taking care of static electricity.

Precautions in peeling off the laminator.

A) Working environment

When the laminator is peeled off, static electricity may cause dust to stick to the polarizer surface.

To avoid this, the following working environment is desirable.

- a) Floor: Conductive treatment of 1M or more on the tile.
(conductive mat or conductive paint on the tile)
- b) Clean room free from dust and with an adhesive mat on the doorway.
- c) Advisable humidity:50% ~ 70% Advisable temperature:15 ~ 27
- d) Workers shall wear conductive shoes, conductive work clothes, conductive gloves and an earth band.

B) Working procedures

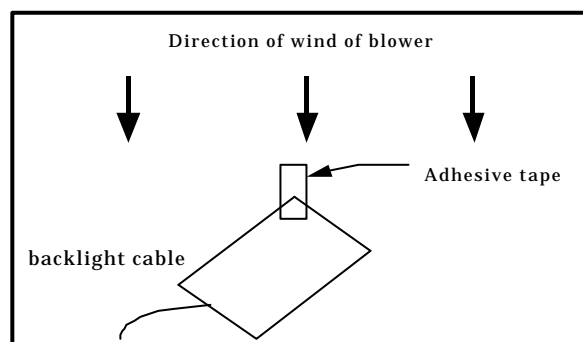
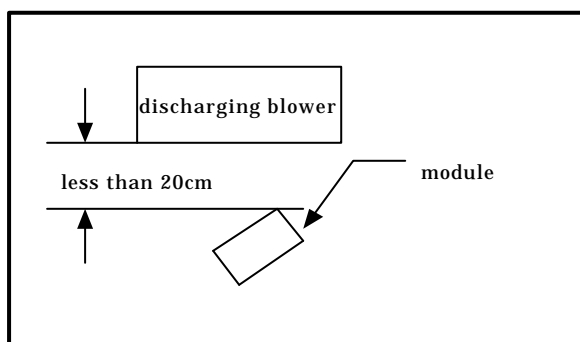

- a) Direct the wind of discharging blower somewhat downward to ensure that module is blown sufficiently.
Keep the distance between module and discharging blower within 20 cm.
- b) Attach adhesive tape to the laminator part near discharging blower so as to protect polarizer against flaw.
- c) Peel off laminator, pulling adhesive tape slowly to your side taking 5 or more second.
- d) On peeling off the laminator, pass the module to the next work process to prevent the module to get dust.

e) Method of removing dust from polarizer

- Blow off dust with N2 blower for which static electricity preventive measure has been taken.
- Since polarizer is vulnerable, wiping should be avoided.
But when the panel has stain or grease, we recommend to use adhesive tape to softly remove them from the panel.

When metal part of the TFT-LCD module (shielding lid and rear case) is soiled, wipe it with soft dry cloth. For stubborn dirties, wipe the part, breathing on it.

Wipe off water drop or finger grease immediately. Long contact with water may cause discoloration or spots.

TFT-LCD module uses glass which breaks or cracks easily if dropped or bumped on hard surface.

Handle with care. Since CMOS LSI is used in this module, take care of static electricity and earth your body when handling.

12-4) Caution of product design

Please following items strictly when the product is designed by using this module.

- The LCD module shall be protected against water salt-water by the waterproof cover.
- Please take measures to interferential radiation from module, to do not interfere surrounding appliances.

12-5) Others

Do not expose the module to direct sunlight or intensive ultraviolet rays for several hours; liquid crystal is deteriorated by ultraviolet rays.

Store the module at a temperature near the room temperature. At lower than the rated storage temperature, liquid crystal solidifies, causing the panel to be damaged. At higher than the rated storage temperature, liquid crystal turns into isotropic liquid and may not recover.

The voltage of beginning electric discharge may over the normal voltage because of leakage current from approach conductor by to draw lump read lead line around.

If LCD panel breaks, there may be a possibility that the liquid crystal escapes from the panel. Since the liquid crystal is injurious, do not put it into the eyes or mouth. When liquid crystal sticks to hands, feet or clothes, wash it out immediately with soap.

Please adjust the Common electrode drive signal DC bias(COM DC) in the final state of the product. Causes the display fineness decrease when not adjusting COM DC.

Observe all other precautionary requirements in handling general electronic components.

13. Packing form

13-1) The packing form figure: See Fig.2

13-2)

- a) Piling number of cartons : MAX 12
- b) Package quantity in one carton : 20 pcs
- c) Carton size : 519mm(W) × 410mm(H) × 154mm(D)
- d) Total mass of one carton filled with full modules: 4.8kg(TYP)
- e) Conditions for storage.

Environment

Temperature : 0 ~ 40

Humidity : 60%RH or less (at 40)

No dew condensation at low temperature and high humidity.

Atmosphere : Harmful gas, such as acid or alkali which bites electronic components and/or wires, must not be detected.

Period : about 3 months

Opening of the package : In order to prevent the LCD module from breakdown by electrostatic charges, please control the room humidity over 50%RH and open the package taking sufficient countermeasures against electrostatic charges, such as earth, etc.

14. Others

14-1) Indication of lot number

Attached location of the label : See Fig.1 (Outline Dimensions).

Indicated contents of the label

LQ065Y5DG01

model No. lot No.

contents of lot No.	the 1st figure	production year (ex. 2002 : 2)	
	the 2nd figure	production month 1,2,3,	,9,X,Y,Z
	the 3rd ~ 8th figure	serial No. 000001 ~	
	the 9th figure	revision marks A,B,C	

15. Reliability Test Conditions for TFT-LCD Module

Table 15-1

Remark) Temperature condition is based on operating temperature conditions on 6.-Table 6-1.

No.	Test items	Test conditions
1	High temperature storage test	Ta= +85 240h
2	Low temperature storage test	Ta= - 40 240h
3	High temperature and high humidity operating test	Tp=+60 90%RH 240h
4	High temperature operating test	Tp= +85 240h
5	Low temperature operating test	Ta= - 30 240h
6	Electro static discharge test	± 200V · 200pF(0) 1 time for each terminals
7	Shock test	980m/s ² · 6ms, ± X ; ± Y ; ± Z 3 times for each direction (JIS C0041, A-7 Condition C)
8	Vibration test	Frequency range : 8 ~ 33.3Hz, Stroke : 1.3mm Frequency range : 33.3Hz ~ 400Hz, Acceleration : 28.4m/s ² Sweep cycle : 15 minutes X,Z 2 hours for each directions, 4 hours for Y direction 【caution】 (total 8 hours) (JIS D1601)
9	Heat shock test	Ta= - 40 ~ +85 / 200 cycles (0.5h) (0.5h)

【Note】 Ta= Ambient temperature, Tp= Panel temperature

【Check items】 In the standard condition, there shall be no practical problems that may affect the display function.

【caution】 X,Y,Z directions are shown as follows:

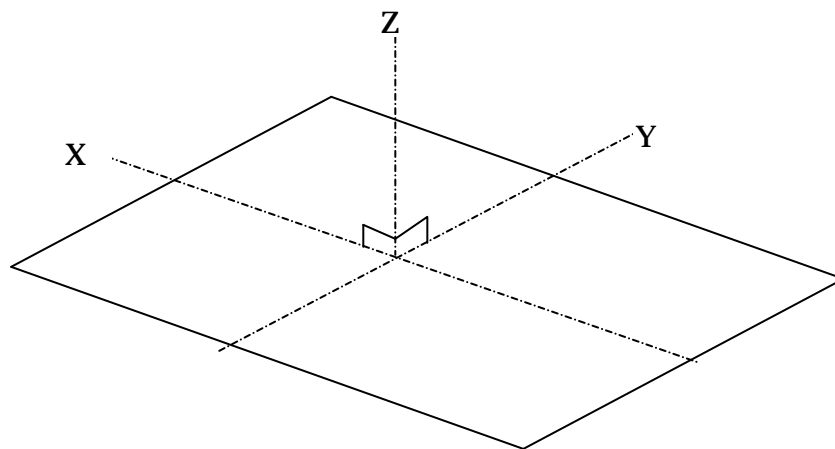

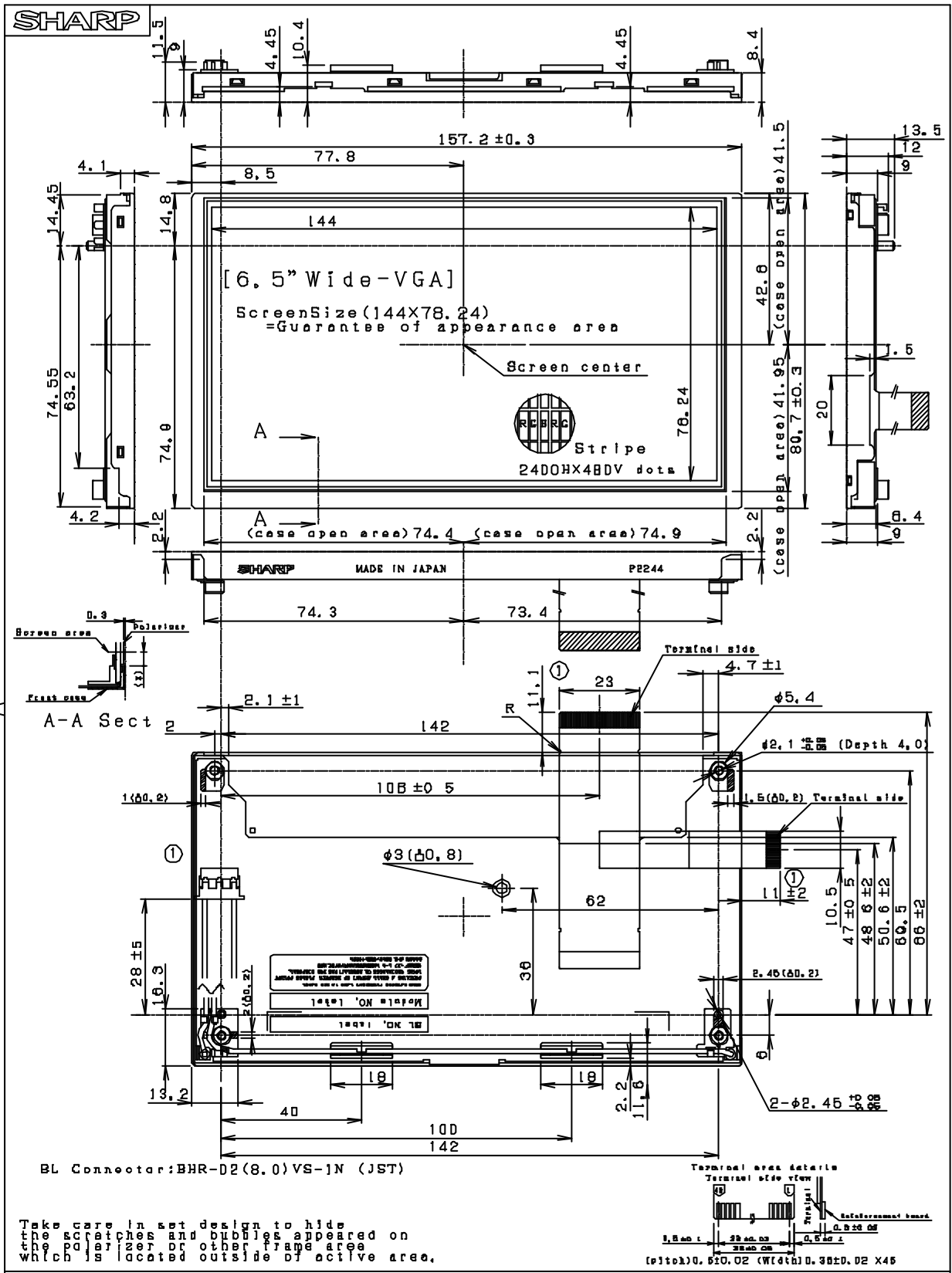

DATE	2002.03.28	SCALE	1:1
MODEL	LC0065Y5DGD1	free	
DRAWING NO	LCM-02036	size	A4
SHARP CO. LTD		MOBILE LCD DESIGN CENTER ENGINEERING DEPT. II	

Fig.1 Outline dimensions

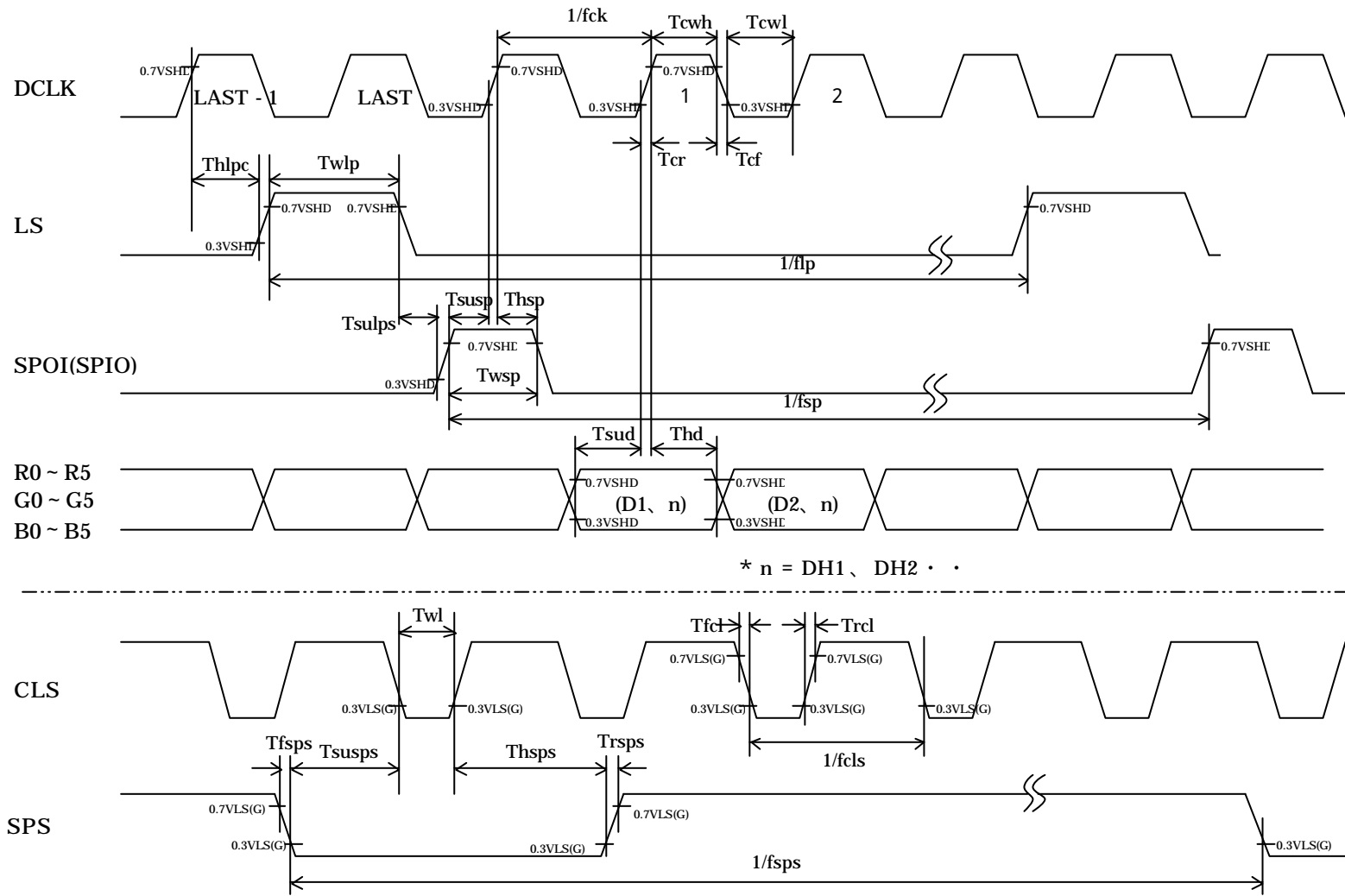

Fig.2-1 Input signal waveform

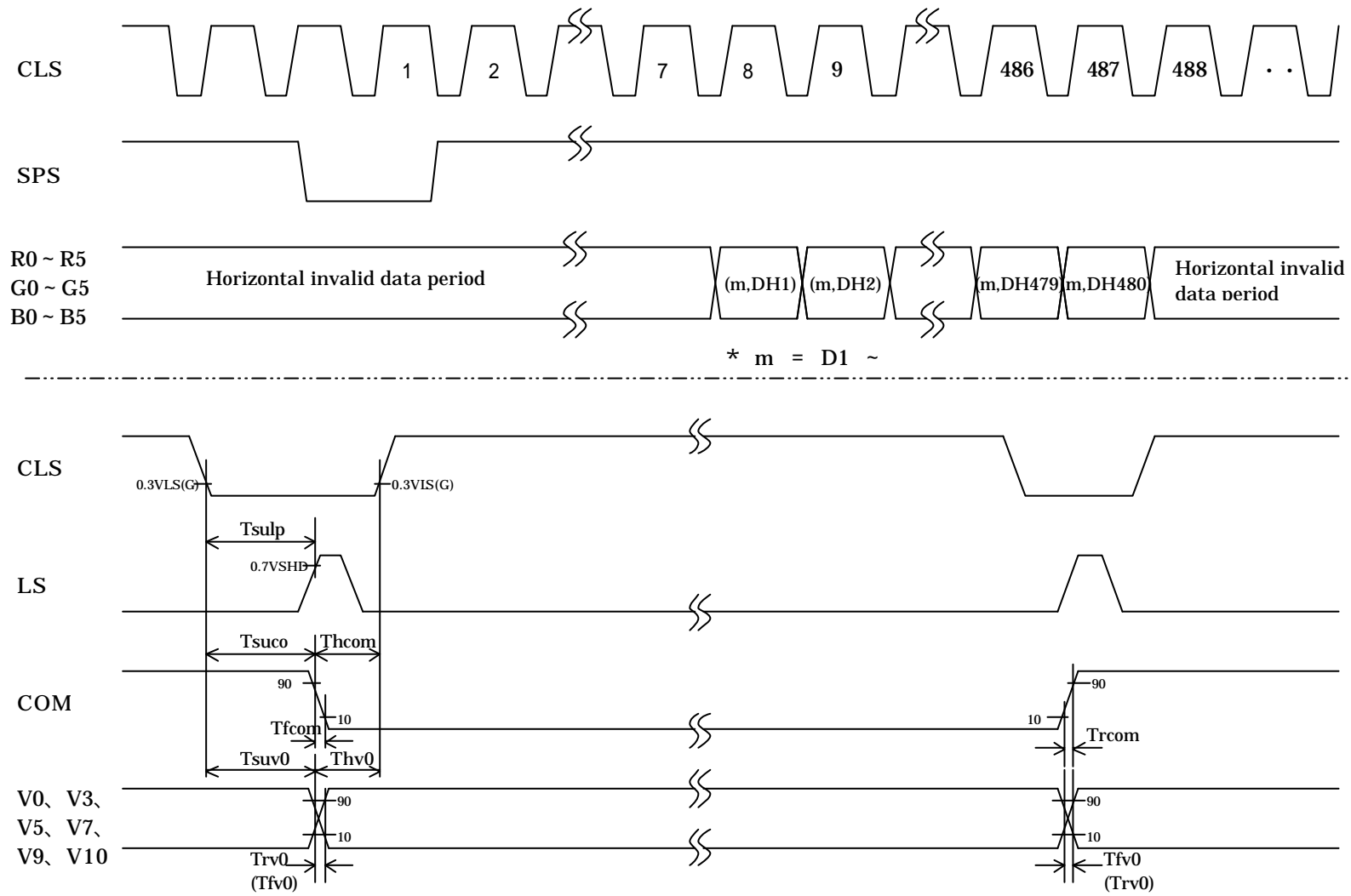

Fig.2-2 Input signal waveform

(Appendix)

Adjusting method of optimum common electrode DC bias voltage

To obtain optimum DC bias voltage of common electrode driving signal (VCDC), photoelectric devices are very effective, and the accuracy is with 0.1V. (In visual examination method, the accuracy is about 0.5V because of the difference among individuals.)

To gain optimum common electrode DC bias, there is the method that uses photoelectric devices.

Measurement of flicker

DC bias voltage is adjusted so as to minimize VSY flicker.

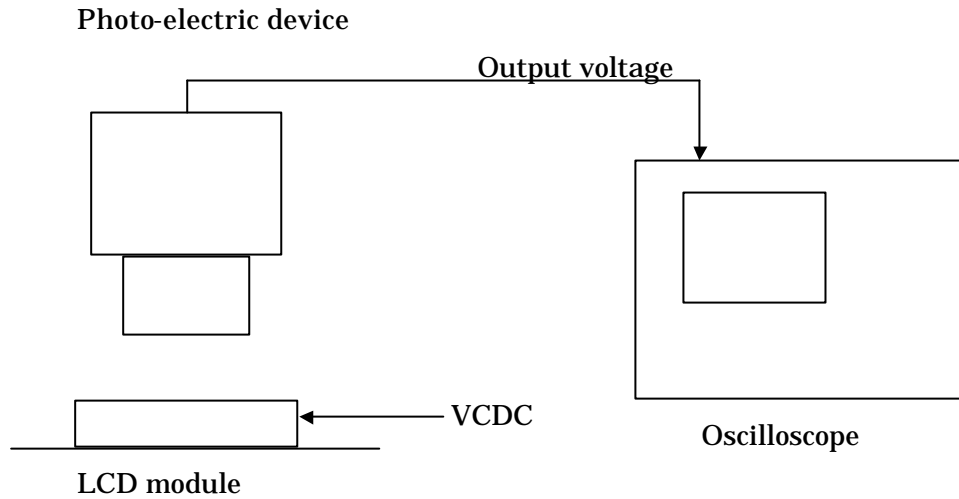

Fig. A Measurement system

《Measurement of flicker》

Photoelectric output voltage is measured by an oscilloscope at a system show in Fig. A.

DC bias voltage must be adjusted so as to minimize the VSY flicker with DC bias voltage changing slowly. (Fig.B)

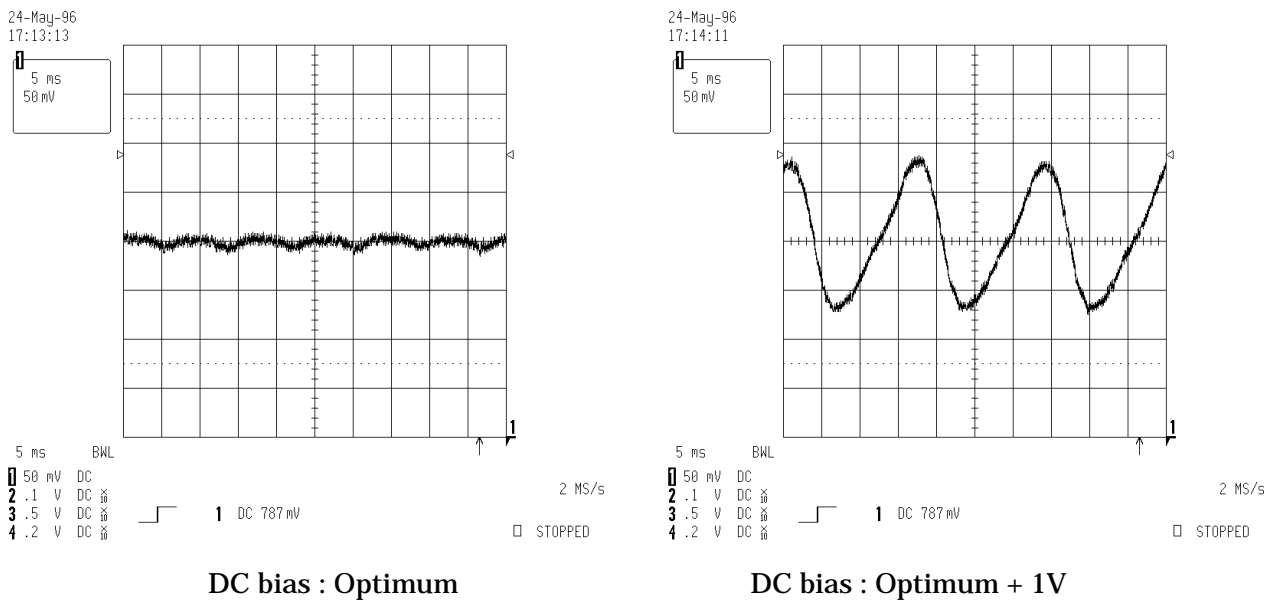

Fig. B Waveforms of flicker